

LBC-4000 L-Band Up/Down Converter System



INTRODUCTION

The LBC-4000 L-Band IF to 70 MHz IF (140 MHz optional) indoor converter is a 1RU 19-inch chassis with two front panel accessible up converter or down converter modules. It contains two diode "OR-ed" internal power supplies, for increased reliability and microprocessor-based Monitor & Control (M&C) functions.

The LBC-4000 up converter module translates a 70 MHz IF input signal (140 MHz optional) up to a user-selected frequency at L-Band (950 to 2000 MHz). The L-Band output can drive the input of the Comtech EF Data MBT-4000 block up converter or other RF equipment with an L-Band input.

The LBC-4000 down converter module translates an L-Band (950 to 2000 MHz) IF input signal down to a user selected frequency in the 70 MHz (140 MHz optional) IF band. The LBC-4000 can be locked to an internal reference or an external 5 or 10 MHz reference signal. The LBC-4000 is an excellent choice for interfacing legacy 70 or 140 MHz equipment to quad-band or tri-band block converters.

FEATURES

- Meets or exceeds MIL-STD-188-164A
- Low phase noise
- 1 kHz step size
- Field selectable spectral inversion
- 50 dB gain adjustment
- 70 ± 18 MHz IF (140 ± 36 MHz optional)
- Flexible configuration
- Auto band sensing capability
- Redundant option available

INSTALLATION

The LBC-4000 is rack mounted in a standard 19-inch equipment rack. External equipment, such as a modem, is connected to each internal converter module by a low-cost coaxial cable. A coaxial cable is also used to connect the output of each module to RF equipment either in the same location or at the antenna location.

MBT-4000 MULTI-BAND RF TRANSCEIVER

A companion to the LBC-4000 is Comtech EF Data's Multi-Band RF Transceiver (MBT-4000), which is designed to perform C-, X-, or Ku-Band RF to L-Band down conversion and L-Band to C-, X-, or Ku-Band RF up conversion. The MBT-4000 features:

- RF Band switching in minimal time without requiring tools
- Automatic band identification for the BUC, BDC, and antenna feed (if the feeds provide an identifying connector)
- Easy system status verification via LEDs located behind a removable cover
- Flexible configuration:
 - 2 ups
 - 2 downs
 - 1 up and 1 down
- Minimal cost for a complete system including spares
- Easy expansion for providing a redundant system or other frequency bands
- Rugged construction for mobile and transportable applications

Please refer to the MBT-4000 datasheet for additional information.

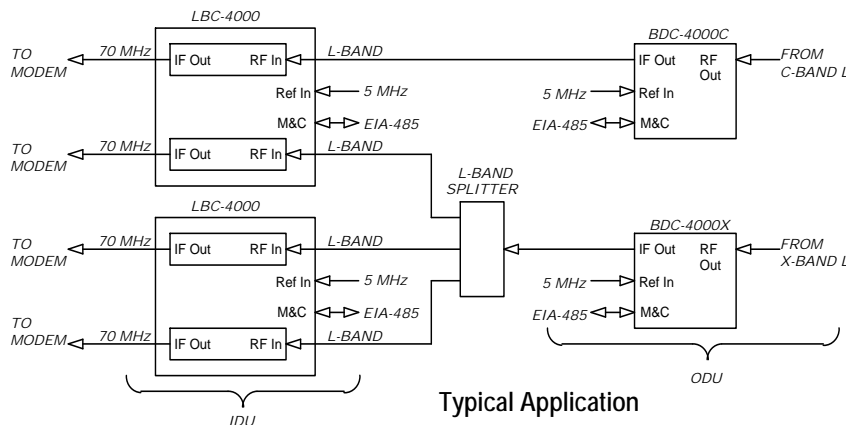

2114 West 7th Street, Tempe, Arizona 85281 USA Voice 1 480 333 2200 Fax 1 480 333 2540 Email sales@comtechefdata.com

Comtech EF Data reserves the right to change specifications of products described in this document at any time without notice and without obligation to notify any person of such changes. Information in this document may differ from that published in other Comtech EF Data documents. Refer to the website or contact Customer Service for the latest released product information.

LBC-4000 L-Band Up/Down Converter System

LBC-4000 L-BAND DOWN CONVERTER IDU

Input Frequency Range	950 to 2000 MHz, 1 kHz steps
Output Frequency	70 ± 18 MHz (140 ± 36 MHz optional)
Input/Output Impedance	50 Ω
Input Return Loss	15 dB minimum
Output Return Loss	20 dB minimum
Input Connector	Type N, Female
Output Connector	BNC, Female
Gain	35 dB nominal at min attenuation
Ripple	± .5 dB over any ± 18 MHz for 70 MHz IF units ± .5 dB over any ± 36 MHz for 140 MHz IF units
Slope	.05 dB/MHz
User Attenuation Range	0 to 40 dB, in 0.25 dB steps (0.1 dB opt)
Output Power, P1dB	+13 dBm minimum
Third Order Intercept	+23 dBm minimum
Carrier Spurious	-60 dBc
Non-Carrier Spurious	-60 dBm
Stability Over Time	± 1 x 10 ⁻⁹ /Day
Stability Over Temp	± 1 x 10 ⁻⁸ 32 to 122°F (0 to 50°C)

LBC-4000 L-BAND UP CONVERTER IDU

Input Frequency	70 ± 18 MHz (140 ± 36 MHz optional)
Output Frequency	950 to 2000 MHz, 1 kHz steps
Input/Output Impedance	50 Ω
Input Return Loss	18 dB minimum
Output Return Loss	15 dB minimum
Input Connector	BNC, Female
Output Connector	N Female
Gain	25 ± 1 dB nominal at minimum attenuation
Ripple	± .5 dB over any ± 18 MHz for 70 MHz IF units ± .5 dB over any ± 36 MHz for 140 MHz IF units
Slope	.05 dB/MHz

LBC-4000 L-BAND UP CONVERTER IDU CONTINUED

User Attenuation Range	0 to 40 dB, in 0.25 dB steps (0.1 dB optional)
Input Power Level	To +10 dBm, maximum
Output Power, P1dB	+10 dBm minimum
Third Order Intercept	+20 dBm minimum
Carrier Spurious	-60 dBc
Non-Carrier Spurious	-75 dBm
Transmit Phase Noise	Exceeds MIL-STD-188-164A
Stability Over Time	± 1 x 10 ⁻⁹ /Day
Stability Over Temp	± 1 x 10 ⁻⁸ 32 to 122°F (0 to 50°C)

PHASE NOISE

Frequency Offset	Up Converter (Guaranteed / Typical)	Down Converter (Guaranteed / Typical)
100 Hz	-75/-78 dBc/Hz	-70/-73 dBc/Hz
1000 Hz	-80/-83 dBc/Hz	-78/-81 dBc/Hz
10000 Hz	-88/-91 dBc/Hz	-87/-90 dBc/Hz
100000 Hz	-108/-111 dBc/Hz	-105/-108 dBc/Hz
1 MHz	-120/-123 dBc/Hz	-119/-122 dBc/Hz

ENVIRONMENTAL

Operating Temperature	-0° to +50°C (32 to 122°F)
Operating Altitude	10,000 ft above sea level
Operating Humidity	5 to 95 non-condensing
Non-Operating Temperature	58° to 160°F (-50 to +71°C)

PHYSICAL

Dissipation	35 W total, 2 converters
Prime Power	90 to 260 VAC, 47 to 63 Hz
Dimensions (1RU) (height x width x depth)	1.75" x 19" x 22" (4.45 x 48.30 x 55.90 cm)
Weight	25 lbs (11.34 kg) maximum

EXTERNAL REFERENCE

Input Frequency	5 or 10 MHz, Auto detect
Input Level	± 5 dBm
Input Impedance	50 Ω

MONITOR & CONTROL

Serial M&C Interface	TIA/EIA-232, TIA/EIA-485, 4-wire
Serial Connector	9-pin D, Female
Alarm Contacts	3 Form C summary
Alarm Connector	9-pin D, Female



LBC-4000 with open front panel

